

Williams® 
ELECTRONICS GAMES, INC.

JULY 1993
16-50017-103

INDIANAJONES

Manual del operador



FLIPPERSPILL.COM

WILLIAMS ELECTRONICS GAMES, INC.
3401 N. CALIFORNIA AVE.
CHICAGO, IL 60618

TABLA DE CONTENIDO

ANILLOS DE GOMA.....	1
RAMPAS.....	2
PIEZAS INFERIORES DE PLAYFIELD.....	3
PIEZAS SUPERIOR DE PLAYFIELD.....	4
UBICACIONES DE PIEZAS SUPERIORES DE PLAYFIELD.....	5
TABLA SOLENOIDE.....	6
UBICACIONES DE SOLENOID	7
MATRIZ DE LÁMPARA	8
LOCALIZACION DE LAMPARAS.....	9
CAMBIAR MATRIZ	10
UBICACIONES DEL INTERRUPTOR	11
MENÚ PRINCIPAL	12
LISTA DE FUSIBLES	13

PIEZAS DE GOMA

<u>Item</u>	<u>Part No.</u>	<u>unidad</u>	<u>descripcion</u>
A	23-6300	16	Anillos goma de 5/16"
B	23-6535	1	Rebote
C	23-6556	10	Goma negra rebote
D	23-6552	2	Goma amarilla rebote
E	23-6308	1	Anillo goma de 3-1/2"
F	23-6306	2	Anillos goma 2-1/2"
G	23-6301	5	Anillos goma 3/4"
H	23-6303	1	Anillo goma 1-1/4"
I	23-6599	2	Anillos goma 7/16"
J	23-6695	2	Goma negra flipper

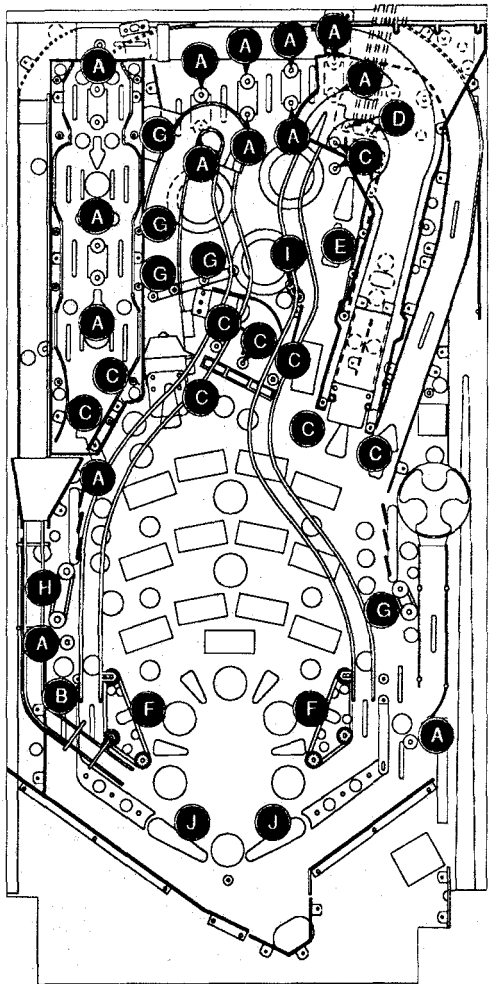

RAMPAS

Item	Part Number	Description
1.	A-16319	Rt. Montaje Rampa plástico
a)	5647-12693-21	Microinterruptor
b)	01-11665	Soporte montaje-Avión combate
c)	A-16707	Avión de combate
d)	A-16909	Opto receptor negro
e)	A-16908	Opto emisor blanco
2.	A-16706	Montaje de rampa de metal
a)	A-16824	Montaje de luz Jackpot
b)	A-16909	Opto emisor led
c)	A-16908	Opto receptor led
d)	5647-12693-21	Microinterruptor
3.	12-7069	Rampa izquierda
4.	12-7070	Rampa Derecha
5.	12-7080	Rampa Parte inferior
6.	A-16863	Montaje de rampa de puente
7.	01-11541	Rampa de metal

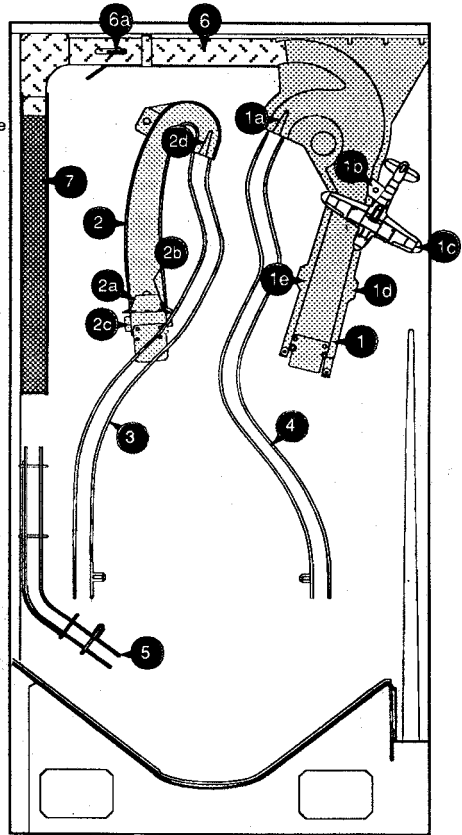

LOCALIZACION DE PARTES BAJO PLAYFIELD

Item Part Number Description

- | | | |
|-----|-------------|-------------------------------------|
| 1. | A-15205-R-2 | Montaje flipper derecho |
| 2. | 01-11781 | Soporte de apoyo (1 drch 1 izq) |
| 3. | A-16765 | Carril de bolas |
| 4. | B-12665 | Rebotador derecho (partes) |
| a) | A-14369-R | Soporte montaje de bobina |
| b) | 10-128 | Muelle |
| c) | B-8284-1 | montaje interruptor rebote |
| 5. | A-15340 | Motor placa EMI (*1) |
| 6. | A-16226 | Bloqueo puerta rotor del Idolo |
| 7. | A-16228 | Conjunto unidad bloqueo rotor |
| 8. | A-16231 | Retenedor de bolas idolo |
| 9. | A-16317 | Canal bolas idolo |
| 10. | A-16637-2 | Mecanismo deslizante, derecho |
| 11. | A-16301 | Conjunto desviador rampa derech |
| 12. | A-14615 | Maquinaria bola prisionera |
| 13. | A-14522 | Topes de bola superior (2 Usado) |
| 14. | A-16739 | Tablero de 4 lámparas |
| 15. | A-94152 | Conjunto de bumpers |
| 16. | B-12030-2 | interruptor paso miniplayfield |
| 17. | 01-10726 | Pata de guía trasera (2 usadas) |
| 18. | A-15946 | placa controladora miniplayfield |
| 19. | A-16637-1 | Mecanismo deslizante, izquierdo |
| 20. | A-15430 | Placa PCB de 10 opto (*2) |
| 21. | A-16929-1 | Maquinaria 3 dianas abatibles |
| 22. | A-17073 | Maquinaria de expulsión de bolas |
| 23. | A-16716-2 | Placa de 38 lámparas |
| 24. | B-12665 | Rebotador izquierdo(partes) |
| a) | A-14369-L | Soporte montaje de bobina |
| b) | 10-128 | Muelle |
| c) | B-8284-1 | montaje interruptor rebote |
| 25. | A-16823 | Placas 3 luces (2 usadas) |
| 26. | A-15205-L-2 | Montaje flipper izquierdo |
| 27. | B-12224 | Placa 1 luz |
| 28. | A-13901-2 | Placa interruptor de rampa opta RFE |

*1- Esta placa controla la interferencia electromagnética

*2-Reduce el consumo de energía en más del 65%

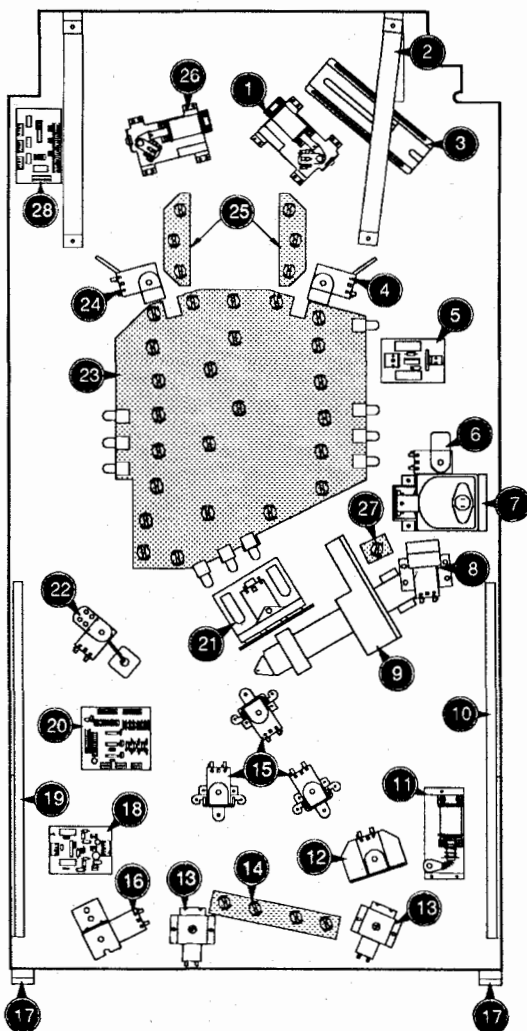

Parte inferior de Playfield, visto en posición levantada

UBICACIONES DE PIEZAS SUPERIORES DE PLAYFIELD

Item	Part Number	Description	Item	Part Number	Description
1	A-14525	Tirador	40	A-15205-L-2	Flipper
2	A-16765	carril de bolas	40a)	20-9250-5	Flipper eje
3	A-15205-R-2	Flipper	41	A-9415-2	Bumper
3a)	20-9250-5	Flipper eje	42	A-17073	Expulsor de bolas
4	A-16911-1	Flipper Guia de bolas	42a)	A-9381-L	microinterruptores expulsión
5	A-16918	montaje puerta de bola	43	A-16710	Plasticos 2 piezas ruinas
6	A-14369-R	Rebotador derecho	44	A-13204-50017	Montaje arco inferior
6a)	B-12665	Rebotador Goma			
7	12-6466-6	Guia de alambre			
8	A-16641	Carril de bola			
9	12-7070	Rampa alambre derecha			
10	A-16418	Dianas abatibles			
11	A-16228	Unidad de bloqueo del rotor			
11a)	14-7982	Motor			
11b)	A-16225	Placa Opto Interruptor			
11c)	A-16226	puerta bloqueo rotor			
11d)	A-16227	Opto bloqueo rotor			
11e)	A-16708	Montaje idolo			
12	A-16231	Tobera de bolas			
13	01-11533	Protector rampa derecho			
14	01-11534	Protector rampa izquierdo			
15	A-16707	Montaje avion			
16	A-14615	Diana abatible			
17	A-16654	Opto bola prisionera			
18	A-16302	Guia desviador bola			
19	A-16301	Montaje desviador			
19a)	A-16636	Embolo del desviador			
19b)	A-14185	Brazo desviador			
20	A-16319	Montaje rampa derecha			
21	A-16418	Carril bola cautiva			
22	A-16596-2	Puerta derecha abatible			
22a)	A-14422	Conjunto bobina			
23	A-16863	Rampa de metal			
24	A-16596-1	Puerta izquierda abatible			
24a)	A-14422	Conjunto bobina			
25	A-16738	Unidad accionamiento motor			
25a)	A-16657	Placa opto de motor			
26	A-16656	Montaje poste arriba / abajo			
27	A-16706	Rampa de metal			
28	A-17168	Montaje miniplayfield			
28a)	12-6466-5	Guia de alambre 1-1/4			
28b)	12-6466-2	Guia de alambre 1/2			
28c)	A-16735	Soporte de pivote / Eje			
29	A-16709	Montaje avion			
30	A-16824	Luz Jackpot			
31	A-16816-4	Interruptor de objetivo			
32	01-11541	Rampa recta de metal			
33	01-11542	Canal inclinado metal			
34	A-16032-2	3 dianas abatibles			
35	12-7080	Rampa de alambre inferior			
36	12-7069	Rampa de alambre izquierda			
37	12-6466-1	Guia de alambre			
38	A-14369-L	Rebotador izquierdo			
39	A-16911-2	Flipper Guia de bolas			

Partes debajo del arco inferior

Part Number	Description
31-1008-50017	Arco inferior oculto
12-7090	Cerca de alambre
20-9041	Chapa roscador
20-9601	# 8-32 Retenedor de tuerca



No mostrada

Part Number	Description
A-16765	Ensamblaje completo canal bolas
03-8929-1	Mylar completo Playfield
16-50017-1	Targeta de instrucciones
20-6500	Bolas de acero

El campo de juego de capa dura de INDIANA JONES, no requiere un Mylar completo, sin embargo Mylars se puede comprar a travez de su distribuidor Williams local.

UBICACIONES DE PIEZAS SUPERIORES DE PLAYFIELD

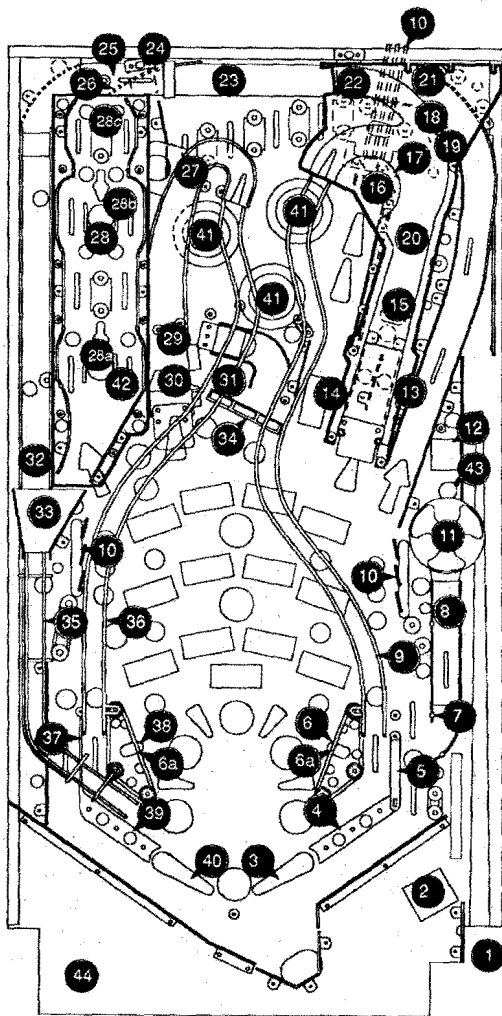

SOLENOID TABLE

Sol. No.	Function	Solenoïd Type	Voltage Connections			Drive Wires	Drive Connections			Drive Wire Color	Solenoïd Part Number	
			Playfield	Backbox	Cabinet		Playfield	Backbox	Cabinet		Playfield	Backbox
01	Ball Popper	High Power	J107-3			033	J130-1			Vio-Brn	AE-26-1200	
02	Ball Launch	High Power	J107-3			030	J130-2			Vio-Red	AE-23-800	
03	Totem Drop Up	High Power	J107-3			073	J130-4			Vio-Orp	AE-26-1200	
04	Ball Release	High Power	J107-3			076	J130-5			Vio-Yel	AE-26-1500	
05	Center Drop Bank	High Power	J107-3			064	J130-6			Vio-Grn	AE-26-1200	
06	Idle Release	High Power	J107-3			066	J130-7			Vio-Blu	AE-26-1500	
07	Knocker	High Power	J107-3			068	J130-8			Vio-Blk	AE-23-800	
08	Left Eject	High Power	J107-3			070	J130-9			Vio-Grv	AE-26-1200	
09	Left Jet Bumper	Low Power	J107-2			058	J127-1			Rn-Blk	AE-26-1200	
10	Right Jet Bumper	Low Power	J107-2			056	J127-3			Rn-Red	AE-26-1200	
11	Bumper Bas	Low Power	J107-2			064	J127-4			Rn-Orp	AE-26-1200	
12	Left Slingshot	Low Power	J107-2			062	J127-5			Rn-Yel	AE-27-1200	
13	Right Slingshot	Low Power	J107-2			060	J127-6			Rn-Grn	AE-27-1200	
14	Left Control Gate	Low Power	J107-2			048	J127-7			Rn-Blu	A-1440-5	
15	Right Control Gate	Low Power	J107-2			046	J127-8			Rn-Vio	A-1440-6	
16	Totem Drop Down	Low Power	J107-2			044	J127-9			Rn-Grv	SM1-26-600	
17	Eternal Life	Flasher	J107-6	J106-5		042	J126-1	J125-1		Blk-Brn	#906 (1)	#906 (3)
18	Light Jackpot	Flasher	J107-6			040	J126-2			Blk-Red	#906 (1)	
19	Super Jackpot	Flasher	J107-6			038	J126-3			Blk-Orp	#89 (1)	
20	Jackpot	Flasher	J107-6	J106-5		036	J126-4	J125-5		Blk-Yel	#89 (1)	#906 (2)
21	Path Of Adventure	Flasher	J107-6	J106-5		028	J126-5	J125-6		Blu-Grn	#89 (1)	#906 (4)
22	Mini Motor Left	Low Power	J118-2			030	J126-6			Blu-Blk		
23	Mini Motor Right	Low Power	J118-2			034	J126-7			Blu-Vio	1-47988	
24	Plane Gun LEDS	Flasher	J118-2	J106-5		032	J126-8	J125-9		Blu-Grv	A-16834	
25	Doofight Hurry Up	Gen. Purpose	J107-6			026	J122-1			Blu-Brn	#89 (1)	
26	Right Ramp	Gen. Purpose	J107-6	J106-5		024	J122-2	J124-2		Blu-Red	#89 (3)	#906 (1)
27	Left Ramp	Gen. Purpose	J107-6	J106-5		022	J122-3	J124-3		Blu-Orp	#89 (1)	#906 (1)
28	Subway Release	Gen. Purpose	J107-1			020	J122-4			Blu-Yel	A-26-1500	
29-36	<i>See Flipper Circuits</i>											
37	Left Side Flasher	Low Power	J107-6	J106-5		018	J4-2	J4-2		Brn-Wht	#89 (2)	#906 (1)
38	Right Side Flasher	Low Power	J107-6	J106-5		015	J4-4	J4-4		Blk-Wht	#89 (2)	#906 (1)
39	Special Flasher	Low Power	J107-5			014	J4-5			Org-Wht	#89 (2)	
40	Totem Multiball	Low Power	J107-6			013	J4-6			Yel-Wht	#89 (1)	
41	Jackpot Multiplier Fl.	Low Power	J107-6			09	J3-2			Grn-Wht	#89 (1)	
42	WHEEL Motor	Low Power	J118-2			010	J3-3			Blu-Wht	14-7982	

*Note: Controlled from the B-Driver Board, not the Power Driver Board

General Illumination

01	Top Playfield	G.I.	J121-1			018	J121-7			Wht-Brn	#44	
02	Bottom Playfield	G.I.	J122-2			010	J121-8			Wht-Orp	#44	
03	Insert Top	G.I.		J120-3		014		J120-9		Wht-Yel		#555
04	Insert Bottom	G.I.		J120-4		016		J120-10		Wht-Grn		#355
05	Return Lane/Coin	G.I.	J121-6		J119-3	012	J121-11		J119-1	Wht-Vio	#44	

Flipper Circuits

Sol. No.	Function	Type	Voltage Connections		Drive Transistors	Drive Connections		Drive Wire Color	Coil Part Number	Coil Colors	
			Playfield	Backbox		Playfield	Backbox				
(29)	Lower Right Flipper	Lwr. Rt. Power	J907-7 (Blu-Yel)		O4	J902-13		Blu-Vio			
(30)	Lower Right Flipper	Lwr. Rt. Hold	J907-7 (Blu-Yel)		O11	J902-11			Org-Grn	FL-11629	Blue
(31)	Lower Left Flipper	Lwr. Lt. Power	J907-9 (Gry-Yel)		O3	J902-9		Blu-Gry			
(32)	Lower Left Flipper	Lwr. Lt. Hold	J907-9 (Gry-Yel)		O9	J902-7			Org-Blu	FL-11629	Blue
33	Diverter Power	Up Rt. Power	J907-1 (Blu-Yel)		O2	J902-6		Blk-Yel			
34	Diverter Hold	Up Rt. Hold	J907-1 (Blu-Yel)		O7	J902-4			Org-Vio	FL-11753	Brown
35	Top Lockup Power	Up Lt. Power	J907-4 (Gry-Yel)		O1	J902-3		Blk-Blu			
36	Top Lockup Hold	Up Lt. Hold	J907-4 (Gry-Yel)		O5	J902-1			Org-Grv	A-15943	Brown

SOLENOID LOCALIZACION

Item	Coil/Flasher No.	Assy No.	Description
01	AE-26-1200	A-16231	Rotor bloqueo bola
02	AE-23-800	A-14525	Lanzamiento de bola
03	AE-26-1200	A-14615	Diana totem arriba
04	AE-26-1500	A-16765	Bola al carril
05	AE-26-1200	A-16032-2	Dianas centrales
06	AE-26-1500	A-16226	Lanzamiento del idolo
07	AE-23-800	B-10686-1	Golpe partida extra
08	AE-26-1200	A-17073	Expulsión izquierda
09	AE-26-1200	A-9415-2	Bumper izquierdo
10	AE-26-1200	A-9415-2	Bumper derecha
11	AE-26-1200	A-9415-2	Bumper bajo
12	AE-27-1200	A-14369-L	Tirachinas izquierdo
13	AE-27-1200	A-14369-R	Tirachinas derecho
14	A-14406	A-14422	Puerta control izquierda
15	A-14406	A-14422	Puerta control derecha
16	SM1-26-600	A-14615	Totem desplegable
17	24-8802	A-12336-1	Vida eterna #906
18	24-8802	-----	Backbox #906
18	24-8802	A-16824	Luz Jackpot #906
19	24-8704	A-9302	Super Jackpot #89
20	24-8704	A-8798	Jackpot #89
21	24-8802	-----	Backbox #906
21	24-8704	A-8798	Path Of Adventure #89
22	24-8802	-----	Backbox #906
22	14-7988	A-16738	Mini Motor Izquierdo
23	14-7988	A-16738	Mini Motor Derecho
24	-----	A-16834	Leds pistola avion
24	24-8802	-----	Backbox #906
25	24-8704	A-9359	LUZ Dogfight Hurry Up #89
26	24-8704	LUZ A-8798/A-16861	Rampa derecha #89
27	24-8802	-----	Backbox #906
27	24-8704	A-16861	LUZ Rampa izquierda #89
28	24-8802	-----	Backbox #906
28	AE-26-1500	A-16317	Lanzamiento subteraneo
29 a 36	ver Circuitos Flipper		
37	24-8704	A-8798	izquierdo Flasher #89
37	24-8802	-----	Backbox #906
38	24-8704	A-8798	Derecho Flasher #89
38	24-8802	-----	Backbox #906
39	24-8704	A-9302	Special Flashers #89
40	24-8704	A-9302	Totem Flasher #89
41	24-8704	A-8798	Jackpot Multiplier Fishr
42	14-7982	A-16228	#89 Rueda Motor

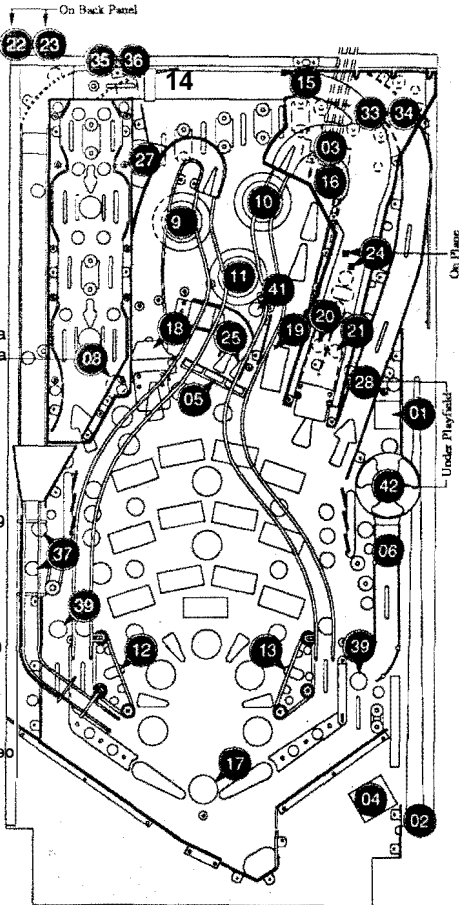

Iluminación general

01	24-6549	-----	*Top Playfield #44
02	24-6549	-----	*Playfield inferior#44
03	24-8768	-----	*Insert Top #555
04	24-8768	-----	*Insert Bottom #555
05	24-6549	-----	*Linea retorno moneda#44

Flippers

29-30	FL-11629	A-15205-R-2	*Flipper inferior derecha
31-32	FL-11629	A-15205-L-2	*Flipper inferior izquierda
33	FL-11753-1	A-16301	Energia del desviador
34	FL-11753-1	A-16301	Sostener desvio
35	A-15943	A-16656	Energia de bloqueo superior
36	A-15943	A-16656	Bloqueo de bloqueo superior

* No mostrada

MATRIZ DE LUCES

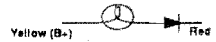

Column \ Row	1 Yellow-Brown J137-1 Q88	2 Yellow-Red J137-2 Q87	3 Yellow-Orange J137-3 Q86	4 Yellow-Black J137-4 Q85	5 Yellow-Green J137-5 Q84	6 Yellow-Blue J137-6 Q83	7 Yellow-Violet J137-7 Q82	8 Yellow-Gray J137-8 Q81
1 Red-Brown J133-1 Q80	Mode Start 11	Tank Chase 21	Left Ramp Arrow 31	Mine Cart 41	Choose Wisely 51	(f)ndy 61	Mini Top Left 71	Mini Middle Bottom Left 81
2 Red-Black J133-2 Q89	Hand of Fate 12	Adventure Light 22	Castle Grunewald 32	Ark Jackpot 42	Right Plane Top 52	(n)dy 62	Mini Top Right 72	Mini Middle Bottom Right 82
3 Red-Orange J133-4 Q88	Eject Extra Ball 13	Adventure Light 23	Left Plane Top 33	Raven Bar 43	Rope Bridge 53	(n)dy 63	Mini Middle Top Left 73	Mini Bottom Left 83
4 Red-Yellow J133-5 Q87	Adventure Light 14	Adventure Light 24	Monkey Brains 34	Right Plane Middle 44	Adventure Light 54	(n)dy 64	Mini Middle Top Right 74	Mini Bottom Right 84
5 Red-Green J133-6 Q86	Adventure Light 15	Steal The Stones 25	Left Plane Middle 35	Bonus 6X 45	Adventure Light 55	Willie 65	Mini Top Arrow 75	Mini Bottom Arrow 85
6 Red-Blue J133-7 Q85	Adventure Light 16	Grail Jackpot 26	Sallah 36	Right Plane Bottom 46	Adventure Light 56	Bonus 2X 66	Marion 76	Totem Top Arrow 86
7 Red-Violet J133-8 Q84	Shoot Again 17	Streets Of Cairo 27	Bonus 4X 37	Wall Of Souls 47	The 3 Challenges 57	Shorty 67	Bonus 8X 77	Center Lock 87
8 Red-Gray J133-9 Q83	Get The Idol 18	Stones Jackpot 28	Left Plane Bottom 38	Left Loop 48	Right Loop 58	Right Ramp Arrow 68	Dr. Jones 78	Start Button 88

UBICACIÓN DE BOMBILLAS

Lamp Assy

Item	Bulb No.	No.	Description
11	24-8768	A-16716-2	Mode Start #555
12	24-8768	A-16716-2	Hand of Fate #555
13	24-8768	A-16716-2	Eject Extra Ball #555
14	24-8768	A-16716-2	Ad(v)enture Light #555
15	24-8768	A-16716-2	A(d)venture Light #555
16	24-8768	A-16716-2	(A)dventure Light #555
17	24-8768	A-16716-2	Shoot Again #555
18	24-8768	A-16716-2	Get the Idol #555
21	24-8768	A-16716-2	Tank Chase #555
22	24-8758	A-16716-2	Advent(ure) Light #555
23	24-8768	A-16716-2	Adv(e)nture Light #555
24	24-8768	A-16716-2	Adve(n)ture Light #555
25	24-8768	A-16716-2	Steal the Stones #555
26	24-8768	A-16716-2	Grail Jackpot #555
27	24-8768	A-16716-2	Street of Cairo #555
28	24-8768	A-16716-2	Stones Jackpot #555
31	24-8768	A-16716-2	Left Ramp Arrow #555
32	24-8768	A-16716-2	Castle Grunewald #555
33	24-8768	A-16716-2	Left Plane Top #555
34	24-8768	A-16716-2	Monkey Brains #555
35	24-8768	A-16716-2	Left Plane Middle #555
36	24-8768	A-16716-2	Sallah #555
37	24-8768	A-16716-2	Bonus 4X #555
38	24-8768	A-16716-2	Left Plane Bottom #555
41	24-8768	A-16716-2	Mine Cart #555
42	24-8768	A-16716-2	Ark Jackpot #555
43	24-8768	A-16716-2	Raven Bar #555
44	24-8768	A-16716-2	Right Plane Middle #555
45	24-8768	A-16716-2	Bonus 6X #555
46	24-8768	A-16716-2	Right Plane Bottom #555
47	24-8768	A-16716-2	Well of Souls #555
48	24-6549	A-11754	Left Loop #44
51	24-8768	A-16716-2	Choose Wisely #555
52	24-8768	A-16716-2	Right Plane Top #555
53	24-8768	A-16716-2	Rope Bridge #555
54	24-8768	A-16716-2	Advent(ure) Light #555
55	24-8768	A-16716-2	Adventu(r)e Light #555
56	24-8768	A-16716-2	Adventur(e) Light #555
57	24-8768	A-16716-2	The 3 Challenges #555
58	24-8768	B-15648	Right Loop #555
61	24-8768	A-16739	(I)-N-D-Y #555
62	24-8768	A-16739	I-(N)-D-Y #555
63	24-8768	A-16739	I-N-(D)-Y #555
64	24-8768	A-16739	I-N-D-(Y) #555
65	24-8768	A-16823	Willie #555
66	24-8768	A-16823	Bonus 2X #555
67	24-8768	A-16823	Shorly #555
68	24-6549	A-11754	Right Ramp Arrow #44
71	24-8768	A-16746	Mini Top Left #555
72	24-8768	A-16746	Mini Top Right #555
73	24-8768	A-16746	Mini Mid. Top Left #555
74	24-8768	A-16746	Mini Mid. Top Right #555
75	24-8768	A-16746	Mini Top Arrow #555
76	24-8768	A-16823	Marion #555
77	24-8768	A-16823	Bonus 8X #555
78	24-8768	A-16823	Dr. Jones #555

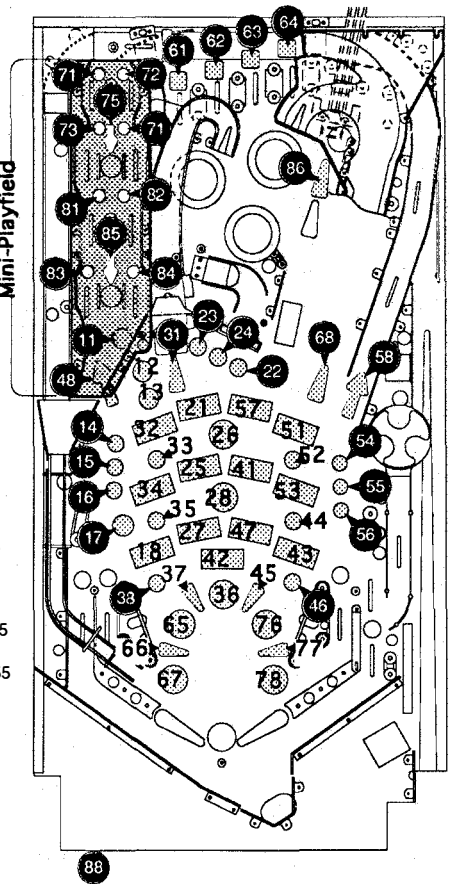

Lamp Assy

Item	Bulb No.	No.	Description
81	24-8768	A-16747	Mini Mid. Bot. Left #555
82	24-8768	A-16747	Mini Mid. Bot. Right #555
83	24-8768	A-16747	Mini Bottom Left #555
84	24-8768	A-16747	Mini Bottom Right #555
85	24-8768	A-16747	Mini Bottom Arrow #555
86	24-6549	A-11754	Totem Top Arrow #44
87	24-6549	A-11754	Center Lock #44
88	-----	20-9663-11	Start Button

SWITCH MATRIX

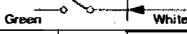
Dedicated Grounded Switches	Column Row										Flipper Grounded Switches
		1 Green-Brown J207-1 U20-18	2 Green-Red J207-2 U20-17	3 Green-Orange J207-3 U20-16	4 Green-Yellow J207-4 U20-15	5 Green-Black J207-5 U20-14	6 Green-Blue J207-6 U20-13	7 Green-Violet J207-7 U20-12	8 Green-Gray J207-9 U20-11	9 Violet-White Q11 JS-4	
Orange-Brown J205-1 Left Coin Chute D1	White-Brown J209-1 U18-11	Single Drop Top 11	Slam Tilt 21	Left Eject 31	Left Ramp Enter 41	Adventure Tgt. 51	Adventure Tgt. 61	Captive Ball Frl. 71	Trough 6 81	Wheel Position 1 91	Black-Green JS06-1 Lower Right E.O.S. F1
Orange-Red J205-2 Center Coin Chute D2	White-Red J209-2 U18-9	Buy-in Button 12	Coin Door Closed 22	Exit Idol 32	Right Ramp Enter 42	Adventure Tgt. 52	Adventure Tgt. 62	Mini Top Hole 72	Trough 5 82	Wheel Position 2 92	Blue-Violet JS05-1 Lower Right Opto F2
Orange-Black J205-3 Right Coin Chute D3	White-Orange J209-3 U18-5	Start Button 13	Ticket Opto 23	Left Slingshot 33	Top Idol Enter 43	Adventure Tgt. 53	Adventure Tgt. 63	Mini Bottom Hole 73	Trough 4 83	Wheel Position 3 93	Black-Blue JS06-3 Lower Left E.O.S. F3
Orange-Yellow J205-4 4th Coin Chute D4	White-Yellow J209-4 U18-7	Plumb Bob Tilt 14	Always Closed 24	Gun Trigger 34	Right Popper 44	Left Loop Top 54	Captive Ball Back 64	Right Ramp Made 74	Trough 3 84	Mini Playfield Left Limit 94	Blue-Gray JS05-2 Lower Left Opto F4
Orange-Green J205-6 Normal Function Normal Escape Coin D5	White-Green J209-5 U19-11	Left Outlane 15	(In)dy Lane 25	Left Jet 35	Center Enter 45	Left Loop Bottom 55	Mini Top Left 65	Mini Top Right 75	Trough 2 85	Mini Playfield Right Limit 95	Black-Violet JS06-4 Center Drop Bank Left F5
Orange-Blue J205-7 Normal Function Volley Down D6	White-Blue J209-7 U19-9	Left Return Lane 16	(In)dy Lane 26	Right Jet 36	Top Post 46	Right Loop Top 56	Mini Middle Top Left 66	Mini Middle Top Right 76	Trough 1 86		Black-Yellow JS05-3 Center Drop Bank Middle F6
Orange-Violet J205-8 Normal Function Volley Up D7	White-Violet J209-8 U19-5	Right Return Lane 17	(In)dy Lane 27	Bottom Jet 37	Subway Lockup 47	Right Loop Bottom 57	Mini Middle Bottom Left 67	Mini Middle Bottom Right 77	Top Trough 87		Black-Gray JS06-5 Center Drop Bank Right F7
Orange-Gray J205-9 Normal Function Volley Enter D8	White-Gray J209-9 U19-7	Right Outlane Top 18	(In)dy Lane 28	Center Standup 38	Right Slingshot 48	Right Outlane Bottom 58	Mini Bottom Left 68	Mini Bottom Right 78	Shooter 88		Black-Blue JS05-5 Left Ramp Made F8

*Nota: utilizado como interruptor, que no sean interruptores flipper en este juego.

UBICACIONES DE INTERRUPTORES

Item	Switch No.	Where Used
F1	SW-1A-194	Lwr Rt. Flipper EOS
F2	A-16384-1	Lwr Rt. Flipper Cab.
F3	SW-1A-194	Lwr Lt. Flipper EOS
F4	A-16384-1	Lwr Lt. Flipper Cab.
F5	A-13609	Center Drop Bank Left
F6	A-13609	Center Drop Bank Mid.
F7	A-13609	Center Drop Bank Right
F8	5647-12693-21	Left Ramp Made
11	5647-12693-31	Single Drop Target
12	20-9663-12	Buy-in Button
13	20-9663-11	Start Button
14	A-6502-A	Plumb Bob Tilt
15	A-12688	Left Outlane
16	A-12688	Left Return Lane
17	A-12688	Right Return Lane
18	A-12688-1	Right Outlane Top
21	SW-1A-117	Slam Tilt
22	5643-09288-00	Coin Door Closed
23		Not Used
24	5643-09288-00	↑Always Closed
25	A-12688	(I)ndy Lane
26	A-12688	(I)ndy Lane
27	A-12688	(I)ndy Lane
28	A-12688	(I)ndy Lane
31	5647-12133-11	Left Eject
32	5647-12693-25	Exit Idol
33	SW-1A-114 (kick)	Left Slingshot
34	5647-12133-12	Gun Trigger
35	SW-11A-37	Left Jet Bumper
35	SW-11A-37	Right Jet Bumper
37	SW-11A-37	Bottom Jet Bumper
38	A-16816-4	Center Standup Target
41	A-16908 (LED)	Left Ramp Enter
42	A-16909 (trans.)	
42	A-14231 (LED)	Right Ramp Enter
43	A-14232 (trans.)	
43	A-14231 (LED)	Top Idol Enter
44	A-14232 (trans.)	
44	A-14231 (LED)	Right Popper
45	A-14232 (trans.)	
45	A-14231 (LED)	Center Enter
46	A-14232 (trans.)	
46	5647-12693-56	Top Post
47	A-14231 (LED)	Subway Lockup
47	A-14232 (trans.)	
48	SW-1A-114 (kick)	Right Slingshot
48	SW-1A-120 (score*)	
51	A-14691-4	Advent(ure) Target
52	A-14691-4	Advent(ure) Target
53	A-14691-4	Adventur(e) Target
54	A-12688	Left Loop Top
55	A-12688	Left Loop Bottom
56	A-12688	Right Loop Top
57	A-12688	Right Loop Bottom
58	A-12688	Right Outlane Bottom
61	A-14691-4	(A)dventure Target
62	A-14691-4	(A)dventure Target
63	A-14691-4	Ad(v)enture Target
64	A-16418	Captive Ball Back
65	A-12688	Mini Top Left
66	A-12688	Mini Mid. Top Left
67	A-12688	Mini Mid. Bottom Left
68	A-12688	Mini Bottom Left
71	A-14231 (LED)	Captive Ball Front
72	A-14232 (trans.)	
72	A-16908 (LED)	Mini Top Hole
73	A-16909 (trans.)	
73	A-16908 (LED)	Mini Bottom Hole
74	A-16909 (trans.)	
74	5647-12693-21	Right Ramp Made
75	A-12688-1	Mini Top Right
76	A-12688-1	Mini Mid. Top Right
77	A-12688-1	Mini Mid. Bot. Right
78	A-12688-1	Mini Bottom Right
81	A-16927 (LED)	Trough 6
81	A-16926 (trans.)	
82	A-16927 (LED)	Trough 5
82	A-16926 (trans.)	
83	A-16927 (LED)	Trough 4
83	A-16926 (trans.)	
84	A-16927 (LED)	Trough 3
84	A-16926 (trans.)	

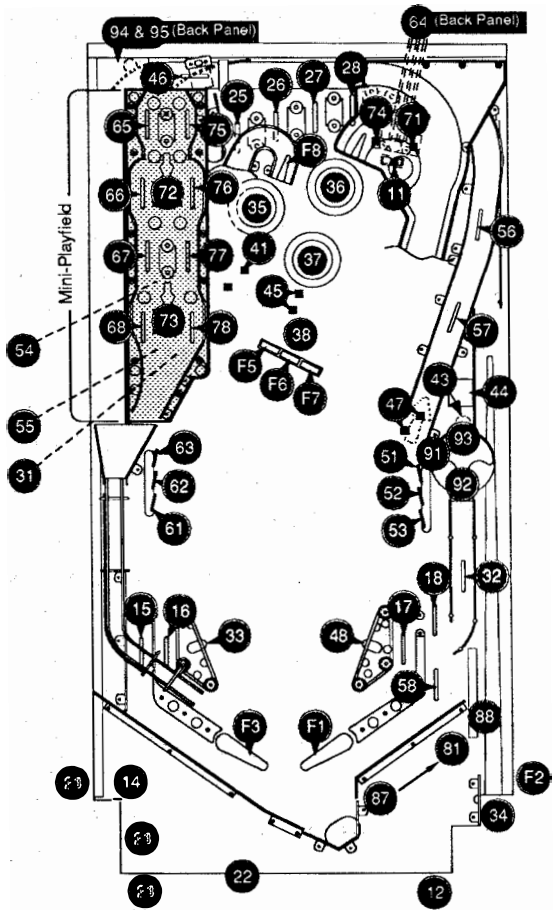

Item	Switch No.	Where Used
85	A-16927 (LED)	Trough 2
85	A-16926 (trans.)	
86	A-16927 (LED)	Trough 1
86	A-16926 (trans.)	
87	A-16927 (LED)	Trough Top
87	A-16926 (trans.)	
88	A-12688	Shooter
91	A-14231 (LED)	Wheel Position 1
91	A-14232 (trans.)	
92	A-14231 (LED)	Wheel Position 2
92	A-14232 (trans.)	
93	A-14231 (LED)	Wheel Position 3
93	A-14232 (trans.)	
94	A-16657	Mini Plfd Right Limit
95	A-16657	Mini Plfd Left Limit

† No mostrada

Los interruptores de tirachinas de puntaje tienen diodos a través de ellos.

CONFIGURACION Y MENÚ PRINCIPAL

Este juego opera en un sistema de menú. El menú principal le permite elegir entre varias categorías principales, que a su vez conducen a otros menús para elegir. Para ingresar al Sistema de menús, abra la puerta de monedas y presione el botón Comenzar prueba. Las pantallas muestran el juego I.D. Modo. Presione el botón Enter y aparecerá el menú principal. Para desplazarse por el Menú principal, (o cualquier otro menú), seleccione el botón Arriba o Abajo. Active cualquier selección presionando el botón Enter cuando aparezca la selección deseada en la pantalla. Vuelva a encender el modo de atracción o una selección de menú previa, presionando el botón Escape. Presione el botón de Inicio para AYUDA en cualquier momento.

MAIN MENU

B. Bookkeeping Menu

- B.1 AUDITORIAS PRINCIPALES
- B.2 AUDITORIAS DE GANANCIAS
- B.3 AUDITORIAS ESTANDARS
- B.4 AUDITORIAS CARACTERISTICAS
- B.5 HISTOGRAMAS
- B.6 SELLOS DE TIEMPO

Press Escape

To move out of a menu selection.

Press Enter

To get into a menu selection.

Press Up

Increases sequence; (ex. A.1, A.2, A.3, A.4).

Press Down

Decreases sequence; (ex. A.4, A.3, A.2, A.1).

P. Printouts Menu

- P.1 Datos de ganancias
- P.2 Auditorias principales
- P.3 Auditorias estándar
- P.4 Auditorias de funciones
- P.5 histogramas de puntuación
- P.6 Histogramas de tiempo
- P.7 Sellos de tiempo
- P.8 Todos los datos

Use Up or Down to cycle through the selections in a menu.

T. Test Menu

- T.1 Cambiar los bordes Prueba
- T.2 Prueba de niveles de conmutación
- T.3 Prueba de interruptores individuales
- T.4 Prueba de solenoide
- T.5 Prueba flasher
- T.6 Prueba iluminacion general
- T.7 Prueba sonido y musica
- T.8 Prueba de lámparas individuales
- T.9 Prueba de todas las lámparas
- T.10 Prueba de lámparas y flasher
- T.11 Prueba de monitor
- T.12 Prueba de bobinas flipper
- T.13 Prueba de lámparas por orden
- T.14 Prueba de bloqueo idolo
- T.15 Prueba de miniplayfield

Use Escape and Enter to move into and out of the selected menu.

U. Utilities Menu

- U.1 Limpiar auditorias
- U.2 Limpiar monedas
- U.3 Limpiar puntuacion
- U.4 Ajustar hora y día
- U.5 Personalizar mensaje
- U.6 establece identificación del juego
- U.7 Ajustes de fabricación
- U.8 Restablecer de fabrica
- U.9 Programar
- U.10 Borrar creditos
- U.11 Prueba total automática

A. Adjustments Menu

- A.1 Ajustes estándar
- A.2 Ajustes características
- A.3 Ajustes de precios
- A.4 Ajustes de historial
- A.5 Ajustes de líneas

LISTA DE FUSIBLES

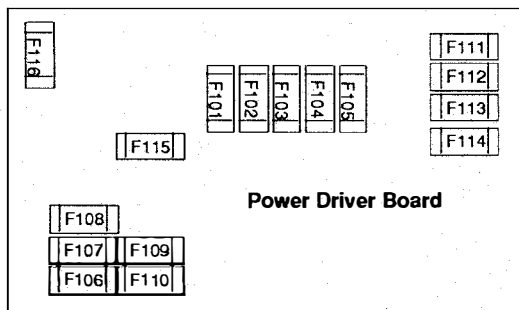
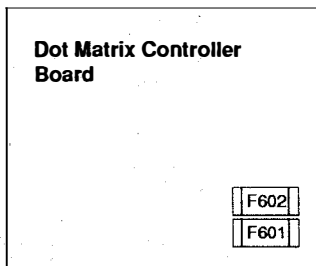
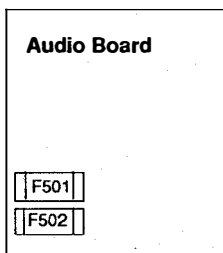
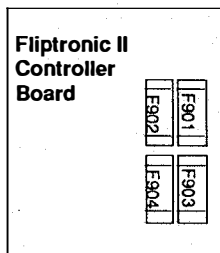

Audio Board

F501 -25V Circuit, 3A, S.B.

F502 +25V Circuit, 3A, S.B.

Dot Matrix Controller Board

F601 +62V Circuit, 3/8A, S.B.

F602 -113V and -125V Circuits, 3/8A, S.B.

Power Driver Board

F101 Left Flipper, 3A, S.B. Not Used

F102 Right Flipper, 3A, S.B. Not Used

F103 Solenoid #25-#28, 3A, S.B.

F104 Solenoid #9-#16, 3A, S.B.

F105 Solenoid #1-#8, 3A, S.B.

F106 G.I. #5 Wht-Vio, 5A, S.B.

F107 G.I. #4 Wht-Grn, 5A, S.B.

F108 G.I. #3 Wht-Yel, 5A, S.B.

F109 G.I. #2 Wht-Org, 5A, S.B.

F110 G.I. #1 Wht-Brn, 5A, S.B.

F111 Flasher Secondary, 5A, S.B.

F112 Solenoid Secondary, 7A, S.B.

F113 +5V Logic, 5A, S.B.

F114 +18V Lamp Matrix, 8A, N.B.

F115 +12V Switch Matrix, 3/4A, S.B.

F116 +12V Secondary, 3A, S.B.

Tarjeta controladora FLiptronic II

F901 FLipper superior derecha, 3A, S.B.

F902 FLipper superior izquierdo, 3A, S.B.

F903 FLipper inferior derecha, 3A, S.B.

F904 FLipper inferior izquierda, 3A, S.B.

Line Filter

Juego doméstico 8A, N.B.

Juego en eL extranjero 5A, S.B.

ADVERTENCIAS Y AVISOS

ADVERTENCIA

PARA SEGURIDAD Y FIABILIDAD, no se recomiendan las modificaciones de piezas y equipos. El uso de partes no-WILLIAMS o modificaciones de los circuitos del juego, puede afectar negativamente el juego o puede causar lesiones.

LA SUSTITUCIÓN DE PIEZAS O EQUIPOS SUSTITUIDOS puede anular la aceptación del tipo de FCC.

DEBIDO A QUE ESTE JUEGO ESTÁ PROTEGIDO por las leyes federales de derechos de autor, marcas comerciales y patentes, las conversiones de juegos no autorizados pueden ser ilegales según las leyes federales.

ESTE PRINCIPIO DE "CONVERSIÓN" TAMBIÉN SE APLICA a facsímiles no autorizados de equipos, logos, diseños, publicaciones, montajes y juegos de WILLIAMS (o funciones del juego que no se consideran de dominio público), ya sean fabricados con componentes de WILLIAMS o no.

NOTICIA

WILLIAMS, Lane-change y Multi-ball son ~~marcas registradas~~ de WILLIAMS ELECTRONICS GAMES, INC. Contenido completo de este manual © 1993 WILLIAMS ELECTRONICS GAMES, INC.



Nota: Este equipo ha sido probado y cumple con los límites para un dispositivo digital de Clase A, de conformidad con la Parte 15 de las Reglas de la FCC. Estos límites están diseñados para proporcionar una protección razonable contra interferencias dañinas cuando el equipo se opera en un entorno comercial. Este equipo genera, usa y puede irradiar energía de radiofrecuencia y, si no se instala y utiliza de acuerdo con el manual de instrucciones, puede causar interferencias perjudiciales a las comunicaciones de radio. El funcionamiento de este equipo en una zona residencial puede causar interferencias perjudiciales, en cuyo caso el usuario deberá corregir la interferencia por su propia cuenta.

Aviso de interferencia de RF

LAS COLOCACIONES DEL ARNÉS DE CABLE y el enrutamiento de la correa de tierra en este juego se han diseñado para mantener la radiación y la conducción de RF dentro de los niveles aceptados por las Reglas de la FCC.

PARA MANTENER ESTOS NIVELES, vuelva a colocar los arneses y vuelva a conectar las correas de tierra a sus ubicaciones originales, si se desconectan durante el mantenimiento.

Asegúrate de que la tarjeta tenga el número de serie musical de tu juego.

Theme Music to:

"Raiders of the Lost Ark,"
©1981 Bartha Music
"Indiana Jones and the Temple of
Doom" © 1984 Bartha Music
"Indiana Jones and the Last
Crusade"
©1989 Bartha Music
(Composer: John Williams)
Used by Permission - All Rights
Reserved



CAUTION

Transport this game ONLY with hinged backbox DOWN!

FOR SERVICE... CALL your authorized WILLIAMS Distributor.

TRADUCIDO POR RIVERTRALLAX